



# **AiP74HC/HCT373**

## **Octal D-type transparent latch; 3-state**

# **Product Specification**

**Specification Revision History:**

<b>Version</b>	<b>Date</b>	<b>Description</b>
2012-06-A1	2012-06	New
2023-04-B1	2023-04	Update the template



# Contents

<b>1、 General Description.....</b>	<b>3</b>
<b>2、 Block Diagram And Pin Description .....</b>	<b>6</b>
2.1、 Block Diagram .....	6
2.2、 Pin Configurations.....	7
2.3、 Pin Description .....	8
2.4、 Function Table.....	8
<b>3、 Electrical Parameter .....</b>	<b>9</b>
3.1、 Absolute Maximum Ratings.....	9
3.2、 Recommended Operating Conditions .....	9
3.3、 Electrical Characteristics .....	10
3.3.1、 DC Characteristics 1 .....	10
3.3.2、 DC Characteristics 2 .....	11
3.3.3、 DC Characteristics 3 .....	12
3.3.4、 AC Characteristics 1 .....	13
3.3.5、 AC Characteristics 2 .....	14
3.3.6、 AC Characteristics 3 .....	15
<b>4、 Testing Circuit .....</b>	<b>16</b>
4.1、 AC Testing Circuit .....	16
4.2、 AC Testing Waveforms.....	17
4.3、 Measurement Points .....	18
4.4、 Test Data .....	18
<b>5、 Package Information .....</b>	<b>19</b>
5.1、 DIP20 .....	19
5.2、 SOP20 .....	20
5.3、 TSSOP20.....	21
<b>6、 Statements And Notes .....</b>	<b>22</b>
6.1、 The name and content of Hazardous substances or Elements in the product .....	22
6.2、 Notes .....	22



## 1、 General Description

The AiP74HC/HCT373 is an octal D-type transparent latch with 3-state outputs. The device features latch enable (LE) and output enable ( $\overline{OE}$ ) inputs. When LE is HIGH, data at the inputs enter the latches. In this condition the latches are transparent, a latch output will change each time its corresponding D-input changes. When LE is LOW the latches store the information that was present at the inputs a set-up time preceding the HIGH-to-LOW transition of LE. A HIGH on  $\overline{OE}$  causes the outputs to assume a high-impedance OFF-state. Operation of the  $\overline{OE}$  input does not affect the state of the latches. Inputs include clamp diodes. This enables the use of current limiting resistors to interface inputs to voltages in excess of  $V_{CC}$ .

### Features:

- Input levels:
  - For AiP74HC373: CMOS level
  - For AiP74HCT373: TTL level
- 3-state non-inverting outputs for bus-oriented applications
- Common 3-state output enable input
- Functionally identical to the AiP74HC/HCT563 and AiP74HC/HCT573
- Specified from -40°C to +125°C
- Packaging information: DIP20/SOP20/TSSOP20

**Ordering Information:****Tube packing specifications:**

Part number	Packaging form	Marking code	Tube quantity	Boxed tube quantity	Boxed quantity	Notes
AiP74HC373DA20.TB	DIP20	74HC373	18 PCS/tube	40 tube/box	720 PCS/box	Dimensions of plastic enclosure: 26.3mm×6.4mm Pin spacing: 2.54mm
AiP74HCT373DA20.TB	DIP20	74HCT373	18 PCS/tube	40 tube/box	720 PCS/box	Dimensions of plastic enclosure: 26.3mm×6.4mm Pin spacing: 2.54mm
AiP74HC373SA20.TB	SOP20	74HC373	35 PCS/tube	80 tube/box	2800 PCS/box	Dimensions of plastic enclosure: 12.8mm×7.5mm Pin spacing: 1.27mm
AiP74HCT373SA20.TB	SOP20	74HCT373	35 PCS/tube	80 tube/box	2800 PCS/box	Dimensions of plastic enclosure: 12.8mm×7.5mm Pin spacing: 1.27mm
AiP74HC373TA20.TB	TSSOP20	74HC373	70 PCS/tube	200 tube/box	14000 PCS/box	Dimensions of plastic enclosure: 6.5mm×4.4mm Pin spacing: 0.65mm
AiP74HCT373TA20.TB	TSSOP20	74HCT373	70 PCS/tube	200 tube/box	14000 PCS/box	Dimensions of plastic enclosure: 6.5mm×4.4mm Pin spacing: 0.65mm



## Reel packing specifications:

Type number	Packaging form	Marking code	Reel quantity	Boxed reel quantity	Notes
AiP74HC373SA20.TR	SOP20	74HC373	2000PCS/reel	2000PCS/box	Dimensions of plastic enclosure: 12.8mm×7.5mm Pin spacing:1.27mm
AiP74HCT373SA20.TR	SOP20	74HCT373	2000PCS/reel	2000PCS/box	Dimensions of plastic enclosure: 12.8mm×7.5mm Pin spacing:1.27mm
AiP74HC373TA20.TR	TSSOP20	74HC373	4000PCS/reel	8000PCS/box	Dimensions of plastic enclosure: 6.5mm×4.4mm Pin spacing:0.65mm
AiP74HCT373TA20.TR	TSSOP20	74HCT373	4000PCS/reel	8000PCS/box	Dimensions of plastic enclosure: 6.5mm×4.4mm Pin spacing:0.65mm

Note: If the physical information is inconsistent with the ordering information, please refer to the actual product.



## 2、Block Diagram And Pin Description

### 2.1、Block Diagram

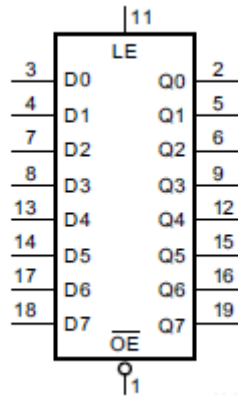

Figure 1. Logic symbol

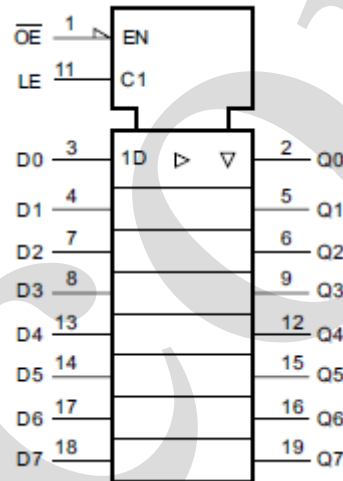

Figure 2. IEC logic symbol

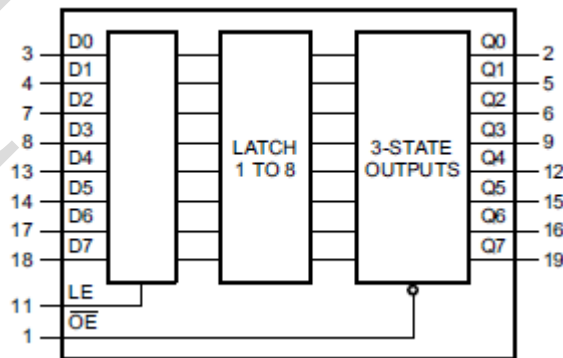

Figure 3. Functional diagram

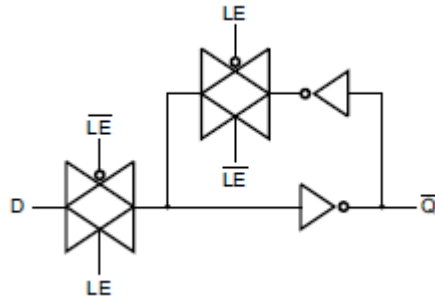

Figure 4. Logic diagram (one latch)

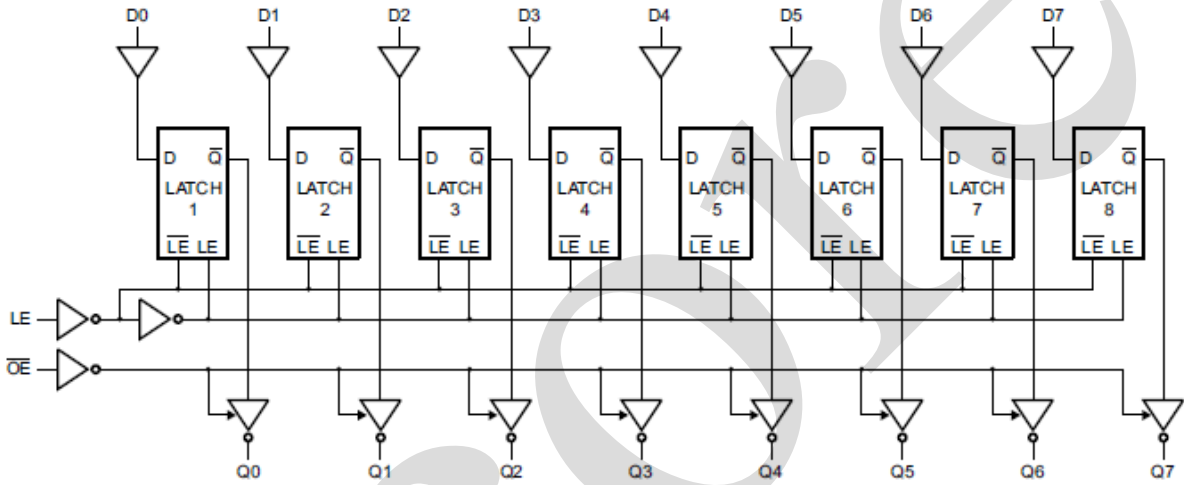
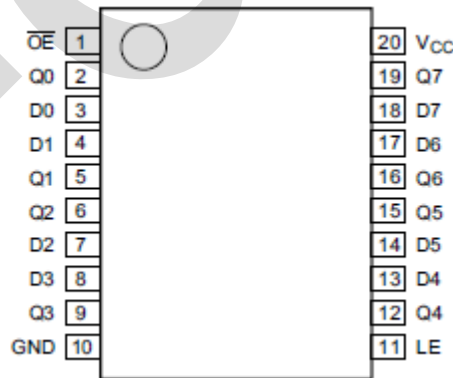

Figure 5. Logic diagram

## 2.2. Pin Configurations





## 2.3、Pin Description

Pin No.	Pin Name	Description
1	$\overline{\text{OE}}$	3-state output enable input (active LOW)
2	Q0	3-state latch output
3	D0	data input
4	D1	data input
5	Q1	3-state latch output
6	Q2	3-state latch output
7	D2	data input
8	D3	data input
9	Q3	3-state latch output
10	GND	ground (0V)
11	LE	latch enable input (active HIGH)
12	Q4	3-state latch output
13	D4	data input
14	D5	data input
15	Q5	3-state latch output
16	Q6	3-state latch output
17	D6	data input
18	D7	data input
19	Q7	3-state latch output
20	V <sub>CC</sub>	supply voltage

## 2.4、Function Table

Operating mode	Control		Input	Internal latches	Output
	$\overline{\text{OE}}$	LE	Dn		Qn
Enable and read register (transparent mode)	L	H	L	L	L
			H	H	H
Latch and read register	L	L	l	L	L
			h	H	H
Latch register and disable outputs	H	X	X	X	Z

Note: H=HIGH voltage level; L=LOW voltage level; Z=high-impedance OFF-state; X=don't care;

h = HIGH voltage level one set-up time prior to the HIGH-to-LOW LE transition;

l = LOW voltage level one set-up time prior to the HIGH-to-LOW LE transition.





## 3、Electrical Parameter

### 3.1、Absolute Maximum Ratings

(Voltages are referenced to GND (ground=0V), unless otherwise specified.)

Parameter	Symbol	Conditions	Min.	Max.	Unit
supply voltage	$V_{CC}$	-	-0.5	+7.0	V
input clamping current	$I_{IK}$	$V_I < -0.5V$ or $V_I > V_{CC}+0.5V$	-	$\pm 20$	mA
output clamping current	$I_{OK}$	$V_O < -0.5V$ or $V_O > V_{CC}+0.5V$	-	$\pm 20$	mA
output current	$I_O$	$V_O = -0.5V$ to $(V_{CC}+0.5V)$	-	$\pm 35$	mA
supply current	$I_{CC}$	-	-	+70	mA
ground current	$I_{GND}$	-	-70	-	mA
storage temperature	$T_{stg}$	-	-65	+150	°C
total power dissipation	$P_{tot}$	-	-	500	mW
Soldering temperature	$T_L$	10s	DIP	245	°C
			SOP/TSSOP	260	

### 3.2、Recommended Operating Conditions

Parameter	Symbol	Conditions	Min.	Typ.	Max.	Unit
<b>AiP74HC373</b>						
supply voltage	$V_{CC}$	-	2.0	5.0	6.0	V
input voltage	$V_I$	-	0	-	$V_{CC}$	V
output voltage	$V_O$	-	0	-	$V_{CC}$	V
input transition rise and fall rate	$\Delta t/\Delta V$	$V_{CC}=2.0V$	-	-	625	ns/V
		$V_{CC}=4.5V$	-	1.67	139	ns/V
		$V_{CC}=6.0V$	-	-	83	ns/V
ambient temperature	$T_{amb}$	-	-40	-	+125	°C
<b>AiP74HCT373</b>						
supply voltage	$V_{CC}$	-	4.5	5.0	5.5	V
input voltage	$V_I$	-	0	-	$V_{CC}$	V
output voltage	$V_O$	-	0	-	$V_{CC}$	V
input transition rise and fall rate	$\Delta t/\Delta V$	$V_{CC}=4.5V$	-	1.67	139	ns/V
ambient temperature	$T_{amb}$	-	-40	-	+125	°C



### 3.3、Electrical Characteristics

#### 3.3.1、DC Characteristics 1

( $T_{amb}=25^{\circ}\text{C}$ , voltages are referenced to GND (ground=0V), unless otherwise specified.)

Parameter	Symbol	Conditions	Min.	Typ.	Max.	Unit	
<b>AiP74HC373</b>							
HIGH-level input voltage	$V_{IH}$	$V_{CC}=2.0\text{V}$	1.5	1.2	-	V	
		$V_{CC}=4.5\text{V}$	3.15	2.4	-	V	
		$V_{CC}=6.0\text{V}$	4.2	3.2	-	V	
LOW-level input voltage	$V_{IL}$	$V_{CC}=2.0\text{V}$	-	0.8	0.5	V	
		$V_{CC}=4.5\text{V}$	-	2.1	1.35	V	
		$V_{CC}=6.0\text{V}$	-	2.8	1.8	V	
HIGH-level output voltage	$V_{OH}$	$V_I = V_{IH} \text{ or } V_{IL}$	$I_O=-20\mu\text{A}; V_{CC}=2.0\text{V}$	1.9	2.0	-	V
			$I_O=-20\mu\text{A}; V_{CC}=4.5\text{V}$	4.4	4.5	-	V
			$I_O=-20\mu\text{A}; V_{CC}=6.0\text{V}$	5.9	6.0	-	V
			$I_O=-6.0\text{mA}; V_{CC}=4.5\text{V}$	3.98	4.32	-	V
			$I_O=-7.8\text{mA}; V_{CC}=6.0\text{V}$	5.48	5.81	-	V
LOW-level output voltage	$V_{OL}$	$V_I = V_{IH} \text{ or } V_{IL}$	$I_O=20\mu\text{A}; V_{CC}=2.0\text{V}$	-	0	0.1	V
			$I_O=20\mu\text{A}; V_{CC}=4.5\text{V}$	-	0	0.1	V
			$I_O=20\mu\text{A}; V_{CC}=6.0\text{V}$	-	0	0.1	V
			$I_O=6.0\text{mA}; V_{CC}=4.5\text{V}$	-	0.15	0.26	V
			$I_O=7.8\text{mA}; V_{CC}=6.0\text{V}$	-	0.16	0.26	V
input leakage current	$I_I$	$V_I=V_{CC} \text{ or } \text{GND}; V_{CC}=6.0\text{V}$	-	-	$\pm 1.0$	$\mu\text{A}$	
OFF-state output current	$I_{OZ}$	$V_I=V_{IH} \text{ or } V_{IL}; V_{CC}=6.0\text{V}; V_O=V_{CC} \text{ or } \text{GND}$	-	-	$\pm 1.0$	$\mu\text{A}$	
supply current	$I_{CC}$	$V_I=V_{CC} \text{ or } \text{GND}; I_O=0\text{A}; V_{CC}=6.0\text{V}$	-	-	8.0	$\mu\text{A}$	
input capacitance	$C_I$	-	-	3.5	-	pF	
<b>AiP74HCT373</b>							
HIGH-level input voltage	$V_{IH}$	$V_{CC}=4.5\text{V to } 5.5\text{V}$	2.0	1.6	-	V	
LOW-level input voltage	$V_{IL}$	$V_{CC}=4.5\text{V to } 5.5\text{V}$	-	1.2	0.8	V	
HIGH-level output voltage	$V_{OH}$	$V_I = V_{IH} \text{ or } V_{IL}; V_{CC}=4.5\text{V}$	$I_O=-20\mu\text{A}$	4.4	4.5	-	V
			$I_O=-6.0\text{mA}$	3.98	4.32	-	V
LOW-level output voltage	$V_{OL}$	$V_I = V_{IH} \text{ or } V_{IL}; V_{CC}=4.5\text{V}$	$I_O=20\mu\text{A}$	-	0	0.1	V
			$I_O=6.0\text{mA}$	-	0.16	0.26	V
input leakage current	$I_I$	$V_I=V_{CC} \text{ or } \text{GND}; V_{CC}=5.5\text{V}$	-	-	$\pm 1.0$	$\mu\text{A}$	
OFF-state output current	$I_{OZ}$	$V_I=V_{IH} \text{ or } V_{IL}; V_{CC}=5.5\text{V}; V_O=V_{CC} \text{ or } \text{GND}$	-	-	$\pm 1.0$	$\mu\text{A}$	
supply current	$I_{CC}$	$V_I=V_{CC} \text{ or } \text{GND}; I_O=0\text{A}; V_{CC}=5.5\text{V}$	-	-	8.0	$\mu\text{A}$	
additional supply current	$\Delta I_{CC}$	per input pin; $V_I=V_{CC}-2.1\text{V};$ other inputs at $V_{CC}$ or GND; $V_{CC}=4.5\text{V to } 5.5\text{V}; I_O=0\text{A}$	Dn inputs	-	-	108	$\mu\text{A}$
			LE input	-	-	540	$\mu\text{A}$
			OE input	-	-	360	$\mu\text{A}$
input	$C_I$	-	-	3.5	-	pF	



capacitance					
-------------	--	--	--	--	--

### 3.3.2、DC Characteristics 2

(T<sub>amb</sub>=-40°C to +85°C, voltages are referenced to GND (ground=0V), unless otherwise specified.)

Parameter	Symbol	Conditions	Min.	Typ.	Max.	Unit	
<b>AiP74HC373</b>							
HIGH-level input voltage	V <sub>IH</sub>	V <sub>CC</sub> =2.0V	1.5	-	-	V	
		V <sub>CC</sub> =4.5V	3.15	-	-	V	
		V <sub>CC</sub> =6.0V	4.2	-	-	V	
LOW-level input voltage	V <sub>IL</sub>	V <sub>CC</sub> =2.0V	-	-	0.5	V	
		V <sub>CC</sub> =4.5V	-	-	1.35	V	
		V <sub>CC</sub> =6.0V	-	-	1.8	V	
HIGH-level output voltage	V <sub>OH</sub>	V <sub>I</sub> = V <sub>IH</sub> or V <sub>IL</sub>	I <sub>O</sub> =-20uA; V <sub>CC</sub> =2.0V	1.9	-	-	V
			I <sub>O</sub> =-20uA; V <sub>CC</sub> =4.5V	4.4	-	-	V
			I <sub>O</sub> =-20uA; V <sub>CC</sub> =6.0V	5.9	-	-	V
			I <sub>O</sub> =-6.0mA; V <sub>CC</sub> =4.5V	3.84	-	-	V
			I <sub>O</sub> =-7.8mA; V <sub>CC</sub> =6.0V	5.34	-	-	V
LOW-level output voltage	V <sub>OL</sub>	V <sub>I</sub> = V <sub>IH</sub> or V <sub>IL</sub>	I <sub>O</sub> =20uA; V <sub>CC</sub> =2.0V	-	-	0.1	V
			I <sub>O</sub> =20uA; V <sub>CC</sub> =4.5V	-	-	0.1	V
			I <sub>O</sub> =20uA; V <sub>CC</sub> =6.0V	-	-	0.1	V
			I <sub>O</sub> =6.0mA; V <sub>CC</sub> =4.5V	-	-	0.33	V
			I <sub>O</sub> =7.8mA; V <sub>CC</sub> =6.0V	-	-	0.33	V
input leakage current	I <sub>I</sub>	V <sub>I</sub> =V <sub>CC</sub> or GND; V <sub>CC</sub> =6.0V	-	-	±1.0	uA	
OFF-state output current	I <sub>OZ</sub>	V <sub>I</sub> =V <sub>IH</sub> or V <sub>IL</sub> ; V <sub>CC</sub> =6.0V; V <sub>O</sub> =V <sub>CC</sub> or GND	-	-	±5.0	uA	
supply current	I <sub>CC</sub>	V <sub>I</sub> =V <sub>CC</sub> or GND; I <sub>O</sub> =0A; V <sub>CC</sub> =6.0V	-	-	80	uA	
<b>AiP74HCT373</b>							
HIGH-level input voltage	V <sub>IH</sub>	V <sub>CC</sub> =4.5V to 5.5V	2.0	-	-	V	
LOW-level input voltage	V <sub>IL</sub>	V <sub>CC</sub> =4.5V to 5.5V	-	-	0.8	V	
HIGH-level output voltage	V <sub>OH</sub>	V <sub>I</sub> = V <sub>IH</sub> or V <sub>IL</sub> ; V <sub>CC</sub> =4.5V	I <sub>O</sub> =-20uA	4.4	-	-	V
			I <sub>O</sub> =-6.0mA	3.84	-	-	V
LOW-level output voltage	V <sub>OL</sub>	V <sub>I</sub> = V <sub>IH</sub> or V <sub>IL</sub> ; V <sub>CC</sub> =4.5V	I <sub>O</sub> =20uA	-	-	0.1	V
			I <sub>O</sub> =6.0mA	-	-	0.33	V
input leakage current	I <sub>I</sub>	V <sub>I</sub> =V <sub>CC</sub> or GND; V <sub>CC</sub> =5.5V	-	-	±1.0	uA	
OFF-state output current	I <sub>OZ</sub>	V <sub>I</sub> =V <sub>IH</sub> or V <sub>IL</sub> ; V <sub>CC</sub> =5.5V; V <sub>O</sub> =V <sub>CC</sub> or GND	-	-	±5.0	uA	
supply current	I <sub>CC</sub>	V <sub>I</sub> =V <sub>CC</sub> or GND; I <sub>O</sub> =0A; V <sub>CC</sub> =5.5V	-	-	80	uA	
additional supply current	ΔI <sub>CC</sub>	per input pin; V <sub>I</sub> =V <sub>CC</sub> -2.1V; other inputs at V <sub>CC</sub> or GND; V <sub>CC</sub> =4.5V to 5.5V; I <sub>O</sub> =0A	Dn inputs	-	-	135	uA
			LE input	-	-	675	uA
			OE input	-	-	450	uA



### 3.3.3、DC Characteristics 3

( $T_{amb} = -40^{\circ}\text{C}$  to  $+125^{\circ}\text{C}$ , voltages are referenced to GND (ground=0V), unless otherwise specified.)

Parameter	Symbol	Conditions	Min.	Typ.	Max.	Unit	
<b>AiP74HC373</b>							
HIGH-level input voltage	$V_{IH}$	$V_{CC}=2.0\text{V}$	1.5	-	-	V	
		$V_{CC}=4.5\text{V}$	3.15	-	-	V	
		$V_{CC}=6.0\text{V}$	4.2	-	-	V	
LOW-level input voltage	$V_{IL}$	$V_{CC}=2.0\text{V}$	-	-	0.5	V	
		$V_{CC}=4.5\text{V}$	-	-	1.35	V	
		$V_{CC}=6.0\text{V}$	-	-	1.8	V	
HIGH-level output voltage	$V_{OH}$	$V_I = V_{IH} \text{ or } V_{IL}$	$I_O = -20\mu\text{A}; V_{CC} = 2.0\text{V}$	1.9	-	-	V
			$I_O = -20\mu\text{A}; V_{CC} = 4.5\text{V}$	4.4	-	-	V
			$I_O = -20\mu\text{A}; V_{CC} = 6.0\text{V}$	5.9	-	-	V
			$I_O = -6.0\text{mA}; V_{CC} = 4.5\text{V}$	3.7	-	-	V
			$I_O = -7.8\text{mA}; V_{CC} = 6.0\text{V}$	5.2	-	-	V
LOW-level output voltage	$V_{OL}$	$V_I = V_{IH} \text{ or } V_{IL}$	$I_O = 20\mu\text{A}; V_{CC} = 2.0\text{V}$	-	-	0.1	V
			$I_O = 20\mu\text{A}; V_{CC} = 4.5\text{V}$	-	-	0.1	V
			$I_O = 20\mu\text{A}; V_{CC} = 6.0\text{V}$	-	-	0.1	V
			$I_O = 6.0\text{mA}; V_{CC} = 4.5\text{V}$	-	-	0.4	V
			$I_O = 7.8\text{mA}; V_{CC} = 6.0\text{V}$	-	-	0.4	V
input leakage current	$I_I$	$V_I = V_{CC} \text{ or } \text{GND}; V_{CC} = 6.0\text{V}$	-	-	$\pm 1.0$	$\mu\text{A}$	
OFF-state output current	$I_{OZ}$	$V_I = V_{IH} \text{ or } V_{IL}; V_{CC} = 6.0\text{V}; V_O = V_{CC} \text{ or } \text{GND}$	-	-	$\pm 10$	$\mu\text{A}$	
supply current	$I_{CC}$	$V_I = V_{CC} \text{ or } \text{GND}; I_O = 0\text{A}; V_{CC} = 6.0\text{V}$	-	-	160	$\mu\text{A}$	
<b>AiP74HCT373</b>							
HIGH-level input voltage	$V_{IH}$	$V_{CC} = 4.5\text{V to } 5.5\text{V}$	2.0	-	-	V	
LOW-level input voltage	$V_{IL}$	$V_{CC} = 4.5\text{V to } 5.5\text{V}$	-	-	0.8	V	
HIGH-level output voltage	$V_{OH}$	$V_I = V_{IH} \text{ or } V_{IL}; V_{CC} = 4.5\text{V}$	$I_O = -20\mu\text{A}$	4.4	-	-	V
			$I_O = -6.0\text{mA}$	3.7	-	-	V
LOW-level output voltage	$V_{OL}$	$V_I = V_{IH} \text{ or } V_{IL}; V_{CC} = 4.5\text{V}$	$I_O = 20\mu\text{A}$	-	-	0.1	V
			$I_O = 6.0\text{mA}$	-	-	0.4	V
input leakage current	$I_I$	$V_I = V_{CC} \text{ or } \text{GND}; V_{CC} = 5.5\text{V}$	-	-	$\pm 1.0$	$\mu\text{A}$	
OFF-state output current	$I_{OZ}$	$V_I = V_{IH} \text{ or } V_{IL}; V_{CC} = 5.5\text{V}; V_O = V_{CC} \text{ or } \text{GND}$	-	-	$\pm 10$	$\mu\text{A}$	
supply current	$I_{CC}$	$V_I = V_{CC} \text{ or } \text{GND}; I_O = 0\text{A}; V_{CC} = 5.5\text{V}$	-	-	160	$\mu\text{A}$	
additional supply current	$\Delta I_{CC}$	per input pin; $V_I = V_{CC} - 2.1\text{V}$ ; other inputs at $V_{CC}$ or GND; $V_{CC} = 4.5\text{V to } 5.5\text{V}; I_O = 0\text{A}$	Dn inputs	-	-	147	$\mu\text{A}$
			LE input	-	-	735	$\mu\text{A}$
			$\overline{\text{OE}}$ input	-	-	490	$\mu\text{A}$



### 3.3.4. AC Characteristics 1

( $T_{amb}=25^{\circ}C$ ,  $GND=0V$ ,  $C_L=50pF$ , unless otherwise specified.)

Parameter	Symbol	Conditions	Min.	Typ.	Max.	Unit	
<b>AiP74HC373</b>							
propagation delay	$t_{pd}$	Dn to Qn; see Figure 7	$V_{CC}=2.0V$	-	41	150	ns
			$V_{CC}=4.5V$	-	15	30	ns
			$V_{CC}=5.0V$ ; $C_L=15pF$	-	12	-	ns
			$V_{CC}=6.0V$	-	12	26	ns
		LE to Qn; see Figure 8	$V_{CC}=2.0V$	-	50	175	ns
			$V_{CC}=4.5V$	-	18	35	ns
			$V_{CC}=5.0V$ ; $C_L=15pF$	-	15	-	ns
			$V_{CC}=6.0V$	-	14	30	ns
$\overline{OE}$ to Qn enable time	$t_{en}$	see Figure 9	$V_{CC}=2.0V$	-	44	150	ns
			$V_{CC}=4.5V$	-	16	30	ns
			$V_{CC}=6.0V$	-	13	26	ns
$\overline{OE}$ to Qn disable time	$t_{dis}$	see Figure 9	$V_{CC}=2.0V$	-	47	150	ns
			$V_{CC}=4.5V$	-	17	30	ns
			$V_{CC}=6.0V$	-	14	26	ns
transition time	$t_t$	Qn; see Figure 7, 8	$V_{CC}=2.0V$	-	14	60	ns
			$V_{CC}=4.5V$	-	5	12	ns
			$V_{CC}=6.0V$	-	4	10	ns
pulse width	$t_w$	LE HIGH; see Figure 8	$V_{CC}=2.0V$	80	17	-	ns
			$V_{CC}=4.5V$	16	6	-	ns
			$V_{CC}=6.0V$	14	5	-	ns
set-up time	$t_{su}$	Dn to LE; see Figure 10	$V_{CC}=2.0V$	50	14	-	ns
			$V_{CC}=4.5V$	10	5	-	ns
			$V_{CC}=6.0V$	9	4	-	ns
hold time	$t_h$	Dn to LE; see Figure 10	$V_{CC}=2.0V$	+5	-8	-	ns
			$V_{CC}=4.5V$	+5	-3	-	ns
			$V_{CC}=6.0V$	+5	-2	-	ns
power dissipation capacitance	$C_{PD}$	per latch; $V_I=GND$ to $V_{CC}$	-	45	-	pF	
<b>AiP74HCT373</b>							
propagation delay	$t_{pd}$	Dn to Qn; see Figure 7	$V_{CC}=4.5V$	-	17	30	ns
			$V_{CC}=5.0V$ ; $C_L=15pF$	-	14	-	ns
		LE to Qn; see Figure 8	$V_{CC}=4.5V$	-	16	32	ns
			$V_{CC}=5.0V$ ; $C_L=15pF$	-	13	-	ns
$\overline{OE}$ to Qn enable time	$t_{en}$	$V_{CC}=4.5V$ ; see Figure 9	-	19	32	ns	
$\overline{OE}$ to Qn disable time	$t_{dis}$	$V_{CC}=4.5V$ ; see Figure 9	-	18	30	ns	
transition time	$t_t$	Qn; $V_{CC}=4.5V$ ; see Figure 7, 8	-	5	12	ns	
pulse width	$t_w$	LE HIGH; $V_{CC}=4.5V$ ; see Figure 8	16	4	-	ns	
Dn to LE set-up time	$t_{su}$	$V_{CC}=4.5V$ ; see Figure 10	12	6	-	ns	



Dn to LE hold time	$t_h$	$V_{CC}=4.5V$ ; see Figure 10	4	-1	-	ns
power dissipation capacitance	$C_{PD}$	per latch; $V_I=GND$ to $V_{CC}-1.5V$	-	41	-	pF

Note:

[1]  $t_{pd}$  is the same as  $t_{PLH}$  and  $t_{PHL}$ .[2]  $t_{en}$  is the same as  $t_{PZL}$  and  $t_{PZH}$ .[3]  $t_{dis}$  is the same as  $t_{PLZ}$  and  $t_{PHZ}$ .[4]  $t_t$  is the same as  $t_{THL}$  and  $t_{TLH}$ .[5]  $C_{PD}$  is used to determine the dynamic power dissipation ( $P_D$  in uW).

$$P_D = C_{PD} \times V_{CC}^2 \times f_i \times N + \sum (C_L \times V_{CC}^2 \times f_o)$$
 where:

 $f_i$ =input frequency in MHz;  $f_o$ =output frequency in MHz; $C_L$ =output load capacitance in pF; $V_{CC}$ =supply voltage in V; $N$ =number of inputs switching; $\sum (C_L \times V_{CC}^2 \times f_o)$ =sum of outputs.

### 3.3.5、 AC Characteristics 2

(T<sub>amb</sub>=-40°C to +85°C, GND=0V, C<sub>L</sub>=50pF, unless otherwise specified.)

Parameter	Symbol	Conditions	Min.	Typ.	Max.	Unit	
<b>AiP74HC373</b>							
propagation delay	$t_{pd}$	Dn to Qn; see Figure 7	$V_{CC}=2.0V$	-	-	190	ns
			$V_{CC}=4.5V$	-	-	38	ns
			$V_{CC}=6.0V$	-	-	33	ns
		LE to Qn; see Figure 8	$V_{CC}=2.0V$	-	-	220	ns
			$V_{CC}=4.5V$	-	-	44	ns
			$V_{CC}=6.0V$	-	-	37	ns
$\overline{OE}$ to Qn enable time	$t_{en}$	see Figure 9	$V_{CC}=2.0V$	-	-	190	ns
			$V_{CC}=4.5V$	-	-	38	ns
			$V_{CC}=6.0V$	-	-	33	ns
$\overline{OE}$ to Qn disable time	$t_{dis}$	see Figure 9	$V_{CC}=2.0V$	-	-	190	ns
			$V_{CC}=4.5V$	-	-	38	ns
			$V_{CC}=6.0V$	-	-	33	ns
transition time	$t_t$	Qn; see Figure 7, 8	$V_{CC}=2.0V$	-	-	75	ns
			$V_{CC}=4.5V$	-	-	15	ns
			$V_{CC}=6.0V$	-	-	13	ns
pulse width	$t_w$	LE HIGH; see Figure 8	$V_{CC}=2.0V$	100	-	-	ns
			$V_{CC}=4.5V$	20	-	-	ns
			$V_{CC}=6.0V$	17	-	-	ns
set-up time	$t_{su}$	Dn to LE; see Figure 10	$V_{CC}=2.0V$	65	-	-	ns
			$V_{CC}=4.5V$	13	-	-	ns
			$V_{CC}=6.0V$	11	-	-	ns
hold time	$t_h$	Dn to LE; see Figure 10	$V_{CC}=2.0V$	5	-	-	ns
			$V_{CC}=4.5V$	5	-	-	ns



		$V_{CC}=6.0V$		5	-	-	ns
<b>AiP74HC373</b>							
propagation delay	$t_{pd}$	Dn to Qn; see Figure 7	$V_{CC}=4.5V$	-	-	38	ns
		LE to Qn; see Figure 8	$V_{CC}=4.5V$	-	-	40	ns
$\overline{OE}$ to Qn enable time	$t_{en}$	$V_{CC}=4.5V$ ; see Figure 9		-	-	40	ns
$\overline{OE}$ to Qn disable time	$t_{dis}$	$V_{CC}=4.5V$ ; see Figure 9		-	-	38	ns
transition time	$t_t$	Qn; $V_{CC}=4.5V$ ; see Figure 7, 8		-	-	15	ns
pulse width	$t_w$	LE HIGH; $V_{CC}=4.5V$ ; see Figure 8		20	-	-	ns
Dn to LE set-up time	$t_{su}$	$V_{CC}=4.5V$ ; see Figure 10		15	-	-	ns
Dn to LE hold time	$t_h$	$V_{CC}=4.5V$ ; see Figure 10		4	-	-	ns

Note:

- [1]  $t_{pd}$  is the same as  $t_{PLH}$  and  $t_{PHL}$ .  
 [2]  $t_{en}$  is the same as  $t_{PZL}$  and  $t_{PZH}$ .  
 [3]  $t_{dis}$  is the same as  $t_{PLZ}$  and  $t_{PHZ}$ .  
 [4]  $t_t$  is the same as  $t_{THL}$  and  $t_{TLH}$ .

### 3.3.6、AC Characteristics 3

(T<sub>amb</sub> = -40°C to +125°C, GND = 0V, C<sub>L</sub> = 50pF, unless otherwise specified.)

Parameter	Symbol	Conditions	Min.	Typ.	Max.	Unit	
<b>AiP74HC373</b>							
propagation delay	$t_{pd}$	Dn to Qn; see Figure 7	$V_{CC}=2.0V$	-	-	225	ns
			$V_{CC}=4.5V$	-	-	45	ns
			$V_{CC}=6.0V$	-	-	38	ns
		LE to Qn; see Figure 8	$V_{CC}=2.0V$	-	-	265	ns
			$V_{CC}=4.5V$	-	-	53	ns
			$V_{CC}=6.0V$	-	-	45	ns
$\overline{OE}$ to Qn enable time	$t_{en}$	see Figure 9	$V_{CC}=2.0V$	-	-	225	ns
			$V_{CC}=4.5V$	-	-	45	ns
			$V_{CC}=6.0V$	-	-	38	ns
$\overline{OE}$ to Qn disable time	$t_{dis}$	see Figure 9	$V_{CC}=2.0V$	-	-	225	ns
			$V_{CC}=4.5V$	-	-	45	ns
			$V_{CC}=6.0V$	-	-	38	ns
transition time	$t_t$	Qn; see Figure 7, 8	$V_{CC}=2.0V$	-	-	90	ns
			$V_{CC}=4.5V$	-	-	18	ns
			$V_{CC}=6.0V$	-	-	15	ns
pulse width	$t_w$	LE HIGH; see Figure 8	$V_{CC}=2.0V$	120	-	-	ns
			$V_{CC}=4.5V$	24	-	-	ns
			$V_{CC}=6.0V$	20	-	-	ns
set-up time	$t_{su}$	Dn to LE; see Figure 10	$V_{CC}=2.0V$	75	-	-	ns
			$V_{CC}=4.5V$	15	-	-	ns



			$V_{CC}=6.0V$	13	-	-	ns
hold time	$t_h$	Dn to LE; see Figure 10	$V_{CC}=2.0V$	5	-	-	ns
			$V_{CC}=4.5V$	5	-	-	ns
			$V_{CC}=6.0V$	5	-	-	ns
<b>AiP74HC373</b>							
propagation delay	$t_{pd}$	Dn to Qn; see Figure 7	$V_{CC}=4.5V$	-	-	45	ns
		LE to Qn; see Figure 8	$V_{CC}=4.5V$	-	-	48	ns
$\overline{OE}$ to Qn enable time	$t_{en}$	$V_{CC}=4.5V$ ; see Figure 9		-	-	48	ns
$\overline{OE}$ to Qn disable time	$t_{dis}$	$V_{CC}=4.5V$ ; see Figure 9		-	-	45	ns
transition time	$t_t$	Qn; $V_{CC}=4.5V$ ; see Figure 7, 8		-	-	18	ns
pulse width	$t_w$	LE HIGH; $V_{CC}=4.5V$ ; see Figure 8		24	-	-	ns
Dn to LE set-up time	$t_{su}$	$V_{CC}=4.5V$ ; see Figure 10		18	-	-	ns
Dn to LE hold time	$t_h$	$V_{CC}=4.5V$ ; see Figure 10		4	-	-	ns

Note:

- [1]  $t_{pd}$  is the same as  $t_{PLH}$  and  $t_{PHL}$ .
- [2]  $t_{en}$  is the same as  $t_{PZL}$  and  $t_{PZH}$ .
- [3]  $t_{dis}$  is the same as  $t_{PLZ}$  and  $t_{PHZ}$ .
- [4]  $t_t$  is the same as  $t_{THL}$  and  $t_{TLH}$ .

## 4、Testing Circuit

### 4.1、AC Testing Circuit

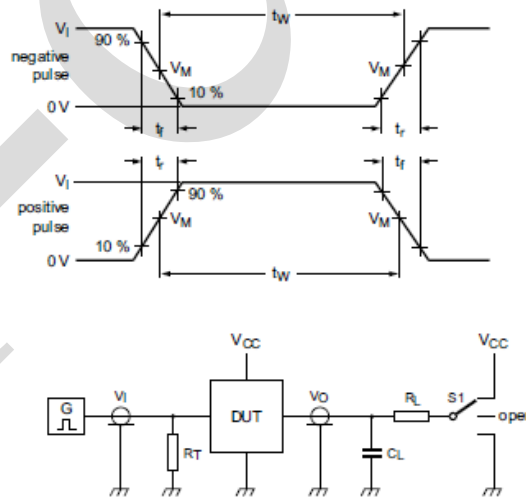

Figure 6. Test circuit for measuring switching times

Definitions for test circuit:

$R_L$ =Load resistance.

$C_L$ =Load capacitance including jig and probe capacitance.

$R_T$ =Termination resistance should be equal to the output impedance  $Z_o$  of the pulse generator.

$S1$ =Test selection switch.





## 4.2、AC Testing Waveforms

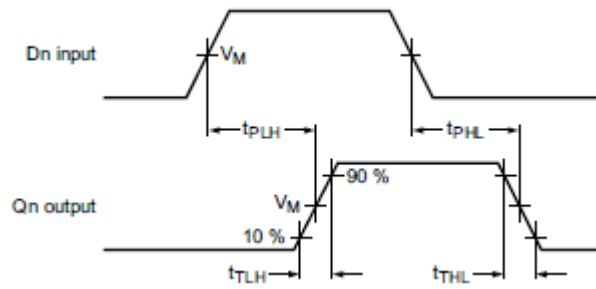

Figure 7. Propagation delay data input (Dn) to output (Qn) and output transition time

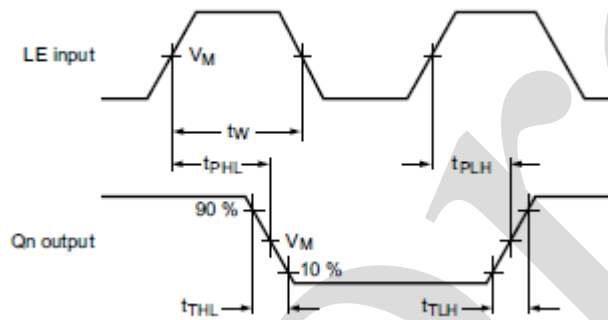

Figure 8. Pulse width latch enable input (LE), propagation delay latch enable input (LE) to output (Qn) and output transition time

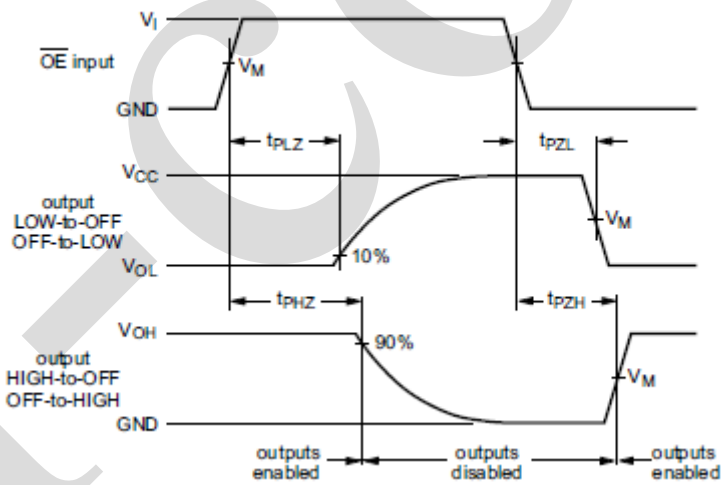

Figure 9. Enable and disable times

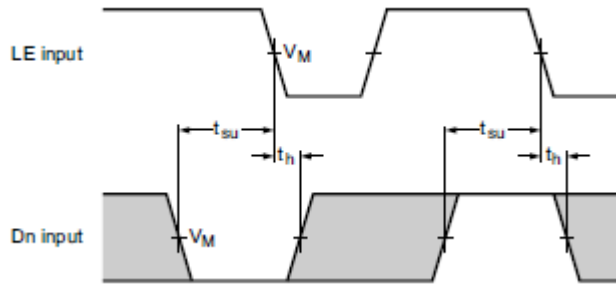

Figure 10. Set-up and hold times for data input (Dn) to latch input (LE)

### 4.3、 Measurement Points

Type	Input	Output
	$V_M$	$V_M$
AiP74HC373	$0.5 \times V_{CC}$	$0.5 \times V_{CC}$
AiP74HCT373	1.3V	1.3V

### 4.4、 Test Data

Type	Input		Load		S1 position		
	$V_I$	$t_r, t_f$	$C_L$	$R_L$	$t_{PHL}, t_{PLH}$	$t_{PZH}, t_{PHZ}$	$t_{PZL}, t_{PLZ}$
AiP74HC373	$V_{CC}$	6ns	15pF, 50pF	1k $\Omega$	open	GND	$V_{CC}$
AiP74HCT373	3V	6ns	15pF, 50pF	1k $\Omega$	open	GND	$V_{CC}$



## 5、Package Information

### 5.1、DIP20

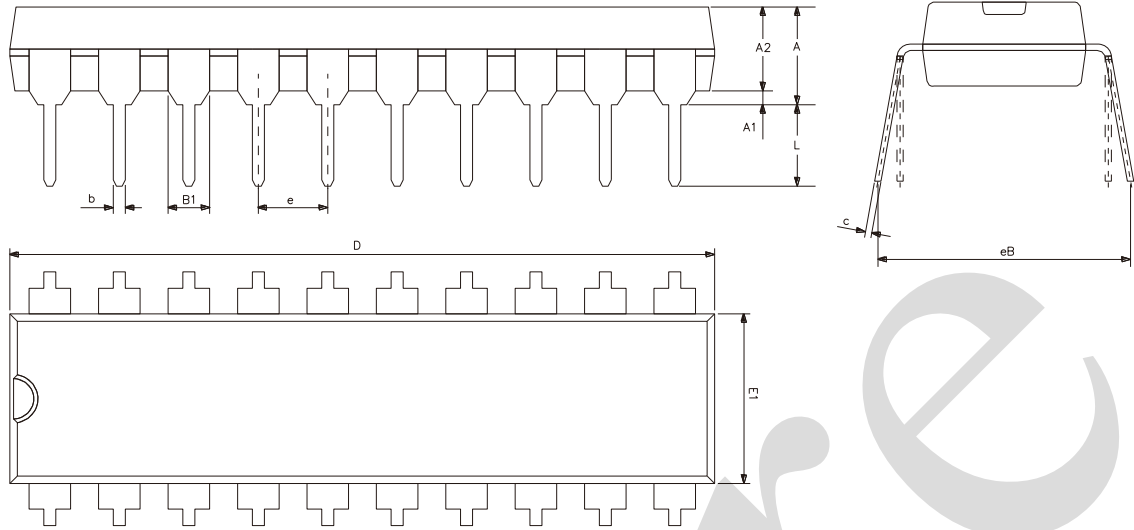

Symbol	Dimensions (mm)	
	Min.	Max.
A	3.60	5.33
A1	0.51	-
A2	3.20	3.60
b	0.36	0.53
B1	1.52	
c	0.204	0.36
D	25.70	26.54
E1	6.20	6.75
e	2.54	
eB	7.62	9.30
L	3.00	3.60



## 5.2、SOP20

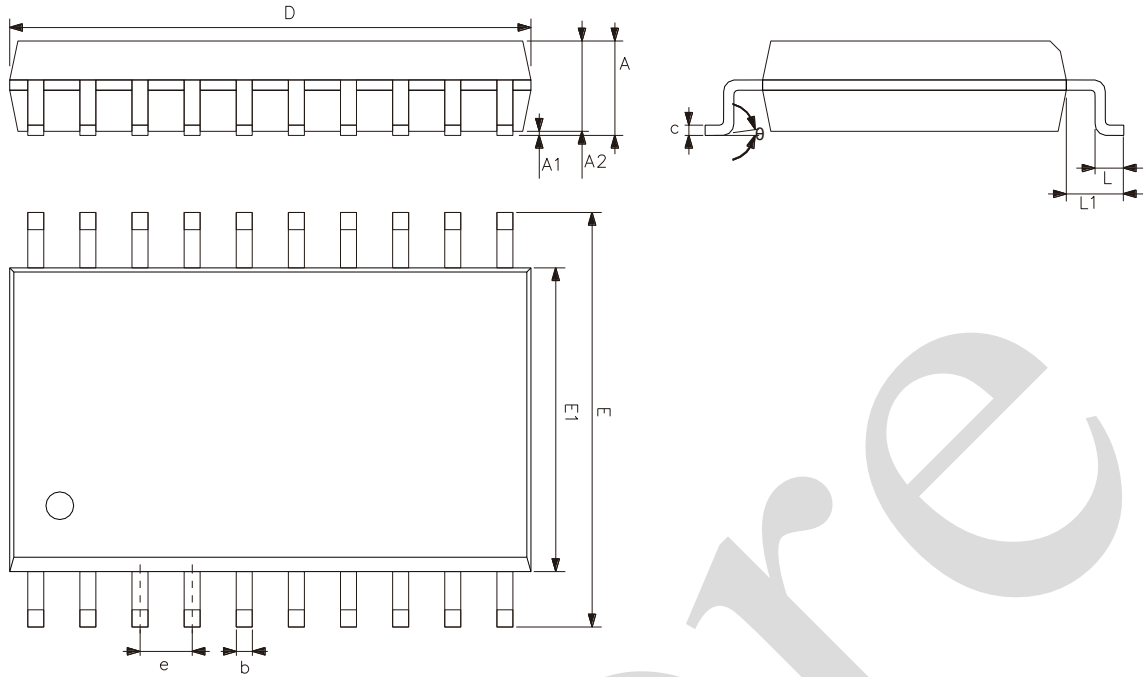

Symbol	Dimensions (mm)	
	Min.	Max.
A	2.47	2.65
A1	0.05	0.30
A2	2.20	2.44
b	0.35	0.50
c	0.15	0.30
D	12.54	12.94
E	10.00	10.60
E1	7.30	7.70
e	1.27	
L	0.40	1.05
L1	1.30	1.50
$\theta$	0°	8°



## 5.3、TSSOP20

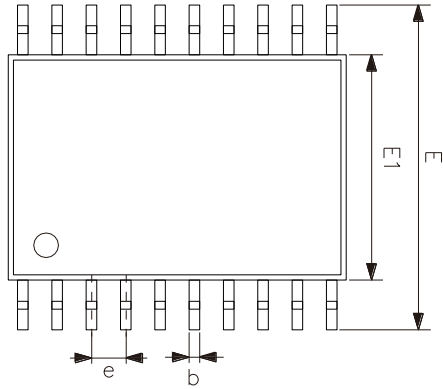
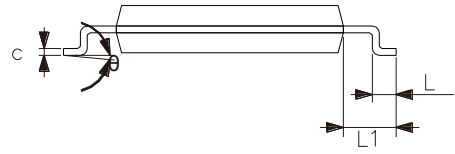
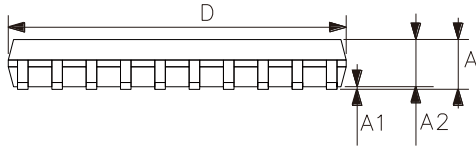

Symbol	Dimensions (mm)	
	Min.	Max.
A	-	1.20
A1	0.05	0.15
A2	0.80	1.05
b	0.19	0.30
c	0.09	0.20
D	6.40	6.60
E1	4.30	4.50
E	6.20	6.60
e	0.65	
L	0.45	0.75
L1	1.00	
$\theta$	0°	8°



## 6、 Statements And Notes

### 6.1、 The name and content of Hazardous substances or Elements in the product

Part name	Hazardous substances or Elements									
	Lead and lead compounds	Mercury and mercury compounds	Cadmium and cadmium compounds	Hexavalent chromium compounds	Polybrominated biphenyls	Polybrominated biphenyl ethers	Dibutyl phthalate	Butylbenzyl phthalate	Di-2-ethylhexyl phthalate	Diisobutyl phthalate
Lead frame	○	○	○	○	○	○	○	○	○	○
Plastic resin	○	○	○	○	○	○	○	○	○	○
Chip	○	○	○	○	○	○	○	○	○	○
The lead	○	○	○	○	○	○	○	○	○	○
Plastic sheet installed	○	○	○	○	○	○	○	○	○	○
explanation	○: Indicates that the content of hazardous substances or elements in the detection limit of the following the SJ/T11363-2006 standard. ×: Indicates that the content of hazardous substances or elements exceeding the SJ/T11363-2006 Standard limit requirements.									

### 6.2、 Notes

We Recommend you to read this chapter carefully before using this product.

The information in this chapter is provided for reference only and i-Core disclaims any express or implied warranties, including but not limited to applicability, special application or non-infringement of third party rights.

This product is not suitable for critical equipment such as life-saving, life-sustaining or safety equipment. It is also not suitable for applications that may result in personal injury, death, or serious property or environmental damage due to product malfunction or failure. I-Core will not be liable for any damages incurred by the customers at their own risk for such applications.

The customer is responsible for conducting all necessary tests i-Core's application to avoid failure in the application or the application of the customer's third party users. I-Core does not accept any liability.

The Company reserves the right to change or improve the information published in this chapter at any time.

The information in this chapter are subject to change without notice. We recommend the customer to consult our sales staff before purchasing.

Please obtain related materials form i-Core's regular channels and we are not responsible for its content if it is provided by sources other than our company.

In case of any conflict between the Chinese and English version, the version is subject to the Chinese one.